

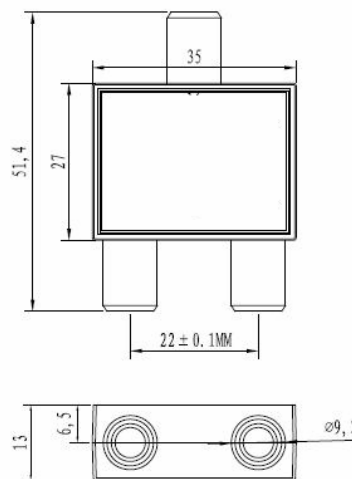

**E877 Front**

**Specifications**

Insertion Loss	5~40MHZ	<0.7dB	
	40~470MHZ	<0.6dB	
	470~862MHZ	<0.8dB	
	862~1000MHZ	<0.9dB	
Insertion Loss	5~1000MHZ	19dB~21dB	
	Return Loss (IN)	5~40MHZ	<-20dB
		40~470MHZ	<-22dB
		470~862MHZ	<-22dB
862~1000MHZ		<-14dB	
Return Loss (OUT)	5~40MHZ	<-20dB	
	40~470MHZ	<-22dB	
	470~862MHZ	<-22dB	
	862~1000MHZ	<-14dB	
Return Loss (TAP)	5~40MHZ	<-20dB	
	40~470MHZ	<-22dB	
	470~862MHZ	<-22dB	
	862~1000MHZ	<-14dB	
Isolation (OUT-TAP)	5~40MHZ	<-36dB	
	40~470MHZ	<-39dB	
	470~862MHZ	<-39dB	
	862~1000MHZ	<-32dB	



Coaxial connectors with screw coupling for use in 75ohm systems.